

SUGGESTED SPECIFICATIONS: _____ projection screen(s), _____(H) x _____(W), To have flexible screen surface, fire retardant and mildew resistant. Screen surface standard with reinforced black binding on all four sides and will attach to frame with metal snaps. Frame will conceal snaps and binding. Screen frame will be 3" wide x 1½" deep with a tapered front

edge to reduce shadows on the viewing surface. Frame to be made of aluminum and finished with black Pro-Trim[®] fabric covering to enhance appearance and absorb light surrounding the viewing area. Frame will be slip-jointed at corners and joints. Standard wall-mounting brackets will be included.

HDTV (16:9) Format Dimensions

| Viewing Area (H x W) | | Nominal Diagonal | | Overall Dimensions | | Approx. Ship. Wt. | |
|----------------------|-----------|------------------|-----|--------------------|-----------|-------------------|------|
| In. | Cm | In. | Cm | In. | Cm | Lbs. | Kg |
| 37½" x 67" | 95 x 170 | 77" | 196 | 43½" x 73" | 110 x 185 | 29 | 13.2 |
| 40½" x 72" | 103 x 183 | 82" | 208 | 46½" x 78" | 118 x 198 | 30 | 13.6 |
| 45" x 80" | 114 x 203 | 92" | 234 | 51" x 86" | 130 x 218 | 34 | 15.4 |
| 49" x 87" | 124 x 221 | 100" | 254 | 55" x 93" | 140 x 236 | 36 | 17.7 |
| 52" x 92" | 132 x 234 | 106" | 269 | 58" x 98" | 147 x 249 | 40 | 18.1 |
| 54" x 96" | 137 x 244 | 110" | 279 | 60" x 102" | 152 x 259 | 41 | 18.6 |
| 58" x 104" | 147 x 264 | 119" | 302 | 64" x 110" | 163 x 279 | 44 | 20 |
| 65" x 116" | 165 x 295 | 133" | 338 | 71" x 122" | 180 x 310 | 49 | 22.2 |
| 78" x 139" | 198 x 353 | 159" | 404 | 84" x 145" | 213 x 368 | 56 | 25.4 |
| 94½" x 168" | 240 x 427 | 193" | 490 | 100½" x 174" | 255 x 442 | 81 | 36.7 |
| 108" x 192" | 274 x 488 | 220" | 559 | 114" x 198" | 290 x 503 | 96 | 43.5 |

Wide (16:10) Format Dimensions

| Viewing Area (H x W) | | Nominal Diagonal | | Overall Dimensions | | Approx. Ship. Wt. | |
|----------------------|-----------|------------------|-----|--------------------|-----------|-------------------|------|
| In. | Cm | In. | Cm | In. | Cm | Lbs. | Kg |
| 50" x 80" | 127 x 203 | 94" | 239 | 56" x 86" | 142 x 218 | 34 | 15.4 |
| 57½" x 92" | 146 x 234 | 109" | 277 | 63½" x 98" | 161 x 249 | 40 | 18.1 |
| 60" x 96" | 152 x 244 | 113" | 287 | 66" x 102" | 168 x 259 | 41 | 18.6 |
| 65" x 104" | 165 x 264 | 123" | 312 | 71" x 110" | 180 x 279 | 44 | 20 |
| 69" x 110" | 175 x 279 | 130" | 330 | 75" x 116" | 191 x 295 | 47 | 21.3 |
| 72½" x 116" | 184 x 295 | 137" | 348 | 78½" x 122" | 199 x 310 | 49 | 22.2 |
| 87" x 139" | 221 x 353 | 164" | 417 | 93" x 145" | 236 x 368 | 56 | 25.4 |
| 100" x 160" | 254 x 406 | 189" | 480 | 106" x 166" | 269 x 422 | 74 | 33.6 |
| 110" x 176" | 249 x 447 | 208" | 528 | 116" x 182" | 295 x 462 | 80 | 36.2 |
| 120" x 192" | 305 x 488 | 226" | 574 | 126" x 198" | 320 x 503 | 96 | 43.5 |

Cinemascope (2.35:1) Format Dimensions

| Viewing Area (H x W) | | Nominal Diagonal | | Overall Dimensions | | Approx. Ship. Wt. | |
|----------------------|-----------|------------------|-----|--------------------|-----------|-------------------|------|
| In. | Cm | In. | Cm | In. | Cm | Lbs. | Kg |
| 37½" x 88" | 95 x 224 | 96" | 244 | 43½" x 94" | 110 x 239 | 36 | 16.3 |
| 40½" x 95" | 103 x 241 | 103" | 262 | 46½" x 101" | 118 x 257 | 41 | 18.6 |
| 45" x 106" | 114 x 269 | 115" | 292 | 51" x 112" | 130 x 284 | 44 | 20 |
| 49" x 115" | 124 x 292 | 125" | 318 | 55" x 121" | 140 x 307 | 49 | 22.2 |
| 52" x 122" | 132 x 310 | 133" | 338 | 58" x 128" | 147 x 325 | 51 | 23.1 |
| 54" x 126" | 137 x 320 | 138" | 351 | 60" x 132" | 152 x 335 | 53 | 24 |
| 58" x 136½" | 147 x 347 | 148" | 376 | 64" x 142½" | 163 x 362 | 55 | 25 |
| 65" x 153" | 165 x 389 | 166" | 422 | 71" x 159" | 180 x 404 | 62 | 28 |
| 78" x 183½" | 198 x 466 | 199" | 505 | 84" x 189½" | 213 x 481 | 91 | 41 |
| 81½" x 192" | 207 x 488 | 208" | 528 | 87½" x 198" | 222 x 503 | 96 | 43.5 |

Video (NTSC 4:3) Format Dimensions

| Viewing Area (H x W) | | Nominal Diagonal | | Overall Dimensions | | Approx. Ship. Wt. | |
|----------------------|-----------|------------------|-----|--------------------|-----------|-------------------|------|
| In. | Cm | In. | Cm | In. | Cm | Lbs. | Kg |
| 36" x 48" | 91 x 122 | 60" | 152 | 42" x 54" | 107 x 137 | 24 | 10.9 |
| 43" x 57½" | 109 x 146 | 72" | 183 | 49" x 63½" | 124 x 161 | 28 | 12.7 |
| 50½" x 67" | 128 x 170 | 84" | 213 | 56½" x 73" | 144 x 185 | 31 | 14.1 |
| 60" x 80" | 152 x 203 | 100" | 254 | 66" x 86" | 168 x 218 | 37 | 16.8 |
| 72" x 96" | 183 x 244 | 120" | 305 | 78" x 102" | 198 x 259 | 45 | 20.4 |
| 90" x 120" | 229 x 305 | 150" | 381 | 96" x 126" | 244 x 320 | 59 | 26.8 |
| 108" x 144" | 274 x 366 | 180" | 457 | 114" x 150" | 290 x 381 | 74 | 33.6 |
| 120" x 160" | 305 x 406 | 200" | 508 | 126" x 166" | 320 x 422 | 89 | 40.4 |
| 144" x 192" | 366 x 488 | 240" | 610 | 150" x 198" | 381 x 503 | 105 | 47.6 |

PRODUCT NOTES

- Overall dimensions +/- 1/4".
- Custom formats and sizes available upon request.
- Specifications subject to change without notice.

SURFACE INFORMATION

- All HD Progressive 0.6, HD Progressive 0.9, HD Progressive 1.1, HD Progressive 1.3, Da-Mat®, High Contrast Da-Mat®, Cinema Vision, High Contrast Cinema Vision, Pearlescent, Da-TeX® and Dual Vision surfaces are seamless up to 16' high.
- HD Progressive 1.1 Perf and High Contrast Cinema Perf are available in sizes up to 8' high.
- **All viewing surfaces are standard with black backing except Da-TeX® and Dual Vision.**

WHEN ORDERING, MARK APPROPRIATE SELECTIONS

1. Select Size from Charts.

2. Select viewing surface (All Da-Lite surfaces are GREENGUARD GOLD Certified.):

- | | |
|--|--|
| <input type="checkbox"/> HD Progressive 0.6 | <input type="checkbox"/> Cinema Vision |
| <input type="checkbox"/> HD Progressive 0.9 | <input type="checkbox"/> High Contrast Cinema Vision |
| <input type="checkbox"/> HD Progressive 1.1 | <input type="checkbox"/> HD Progressive 1.1 Perf |
| <input type="checkbox"/> HD Progressive 1.3 | <input type="checkbox"/> High Contrast Cinema Perf |
| <input type="checkbox"/> Da-Mat® | <input type="checkbox"/> Da-TeX® (Rear) |
| <input type="checkbox"/> High Contrast Da-Mat® | <input type="checkbox"/> Dual Vision |
| <input type="checkbox"/> Pearlescent | |

3. Select Optional Accessories:

- | | |
|---|---|
| <input type="checkbox"/> Veneer Frame Finish (Choose from six standard veneers). | <input type="checkbox"/> Black Textured Powder Coat Finish (Pro-Trim® standard). |
| <input type="checkbox"/> Light Oak | <input type="checkbox"/> T-Legs (must be ordered at the same time as screen). |
| <input type="checkbox"/> Medium Oak | <input type="checkbox"/> Velcro® Attachment (snaps standard). |
| <input type="checkbox"/> Natural Walnut | |
| <input type="checkbox"/> Heritage Walnut | |
| <input type="checkbox"/> Mahogany | |
| <input type="checkbox"/> Cherry | |

PRODUCT VIEW

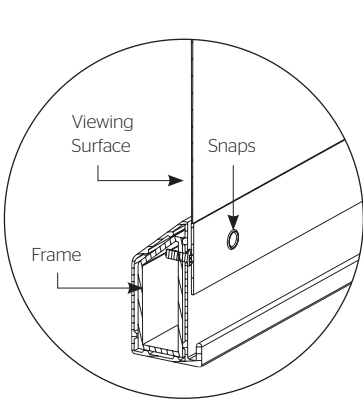

Viewing Surface & Frame Detail

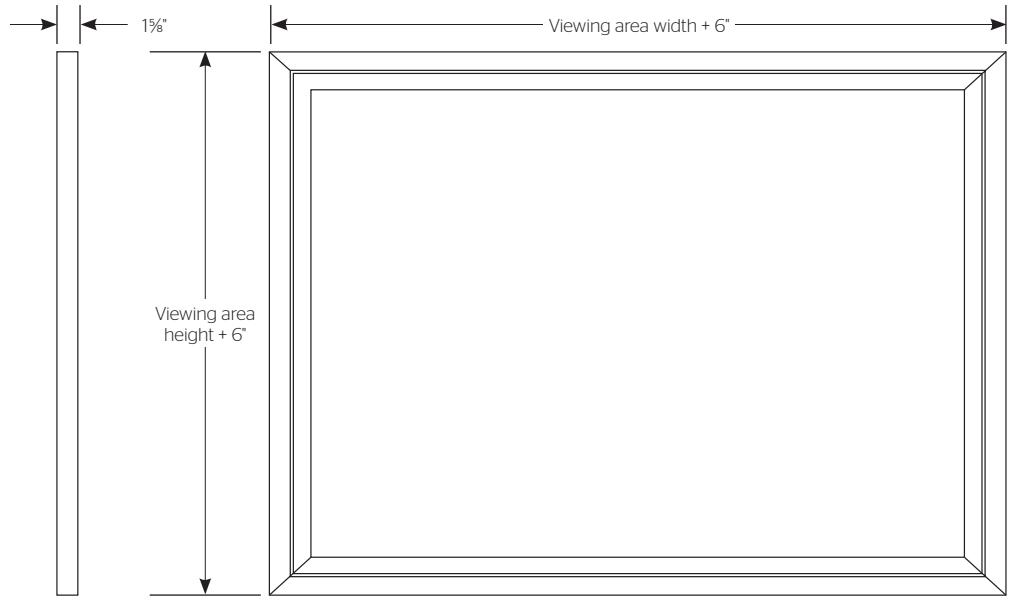

A BRAND OF MILESTONE AV TECHNOLOGIES

www.milestone.com
P 800.622.3737 / 574.267.8101
F 877.325.4832 / 574.267.7804
E info@da-lite.com

In British Columbia, Milestone AV Technologies ULC carries on business as MAVT Milestone AV Technologies ULC.

©2017 Milestone AV Technologies. DL-0149 (Rev. 3) 0517.
 Da-Lite is a registered trademarks of Milestone AV Technologies. All other brand names or marks are used for identification purposes and are trademarks of their respective owners. All patents are protected under existing designations. Other patents pending.

| | |
|---------------------|--------------|
| Project Name: _____ | |
| Architect: _____ | |
| Contractor: _____ | Phone: _____ |
| Reseller: _____ | Phone: _____ |